

Spacecraft SWL – Amphenol QWL

DUST CAPS

& DUMMY RECEPTACLES

SCP101048
SCP101063

SCP101046
SCP101531

SCP10750

- ▶ Special Platings Available
- ▶ Extensive Inventory

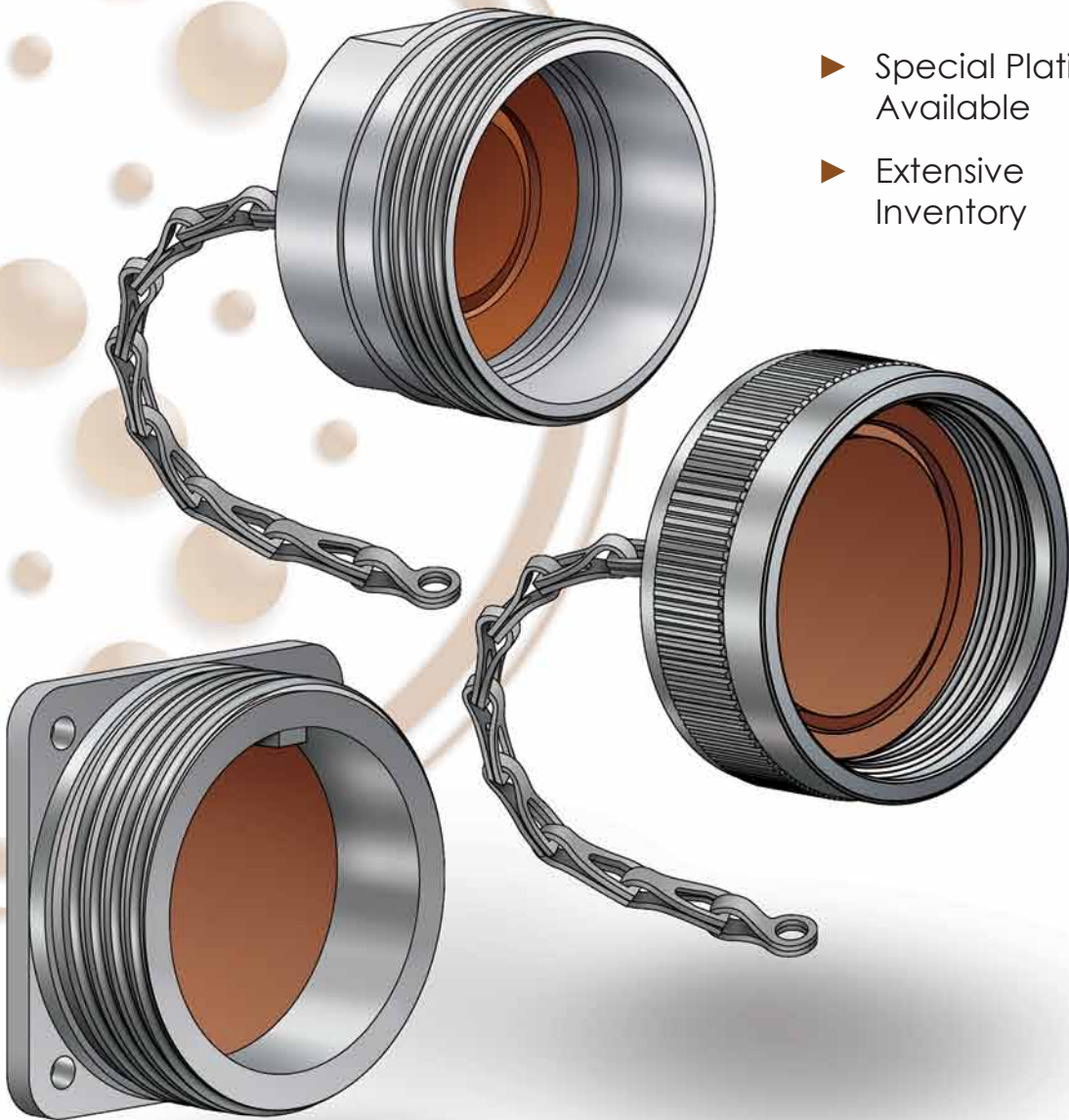

DUST CAPS & DUMMY RECEPTACLES - SPACECRAFT SWL AMPHENOL QWL

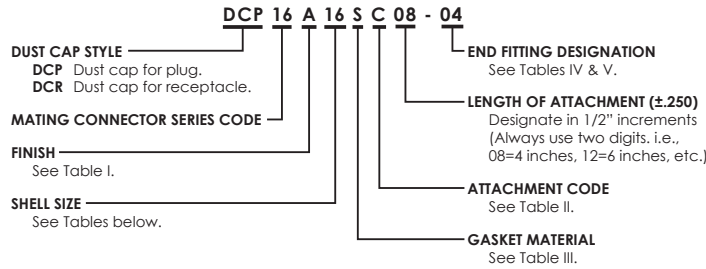

Dust Cap for Plug

SCP101048/SCP101063 DCP16

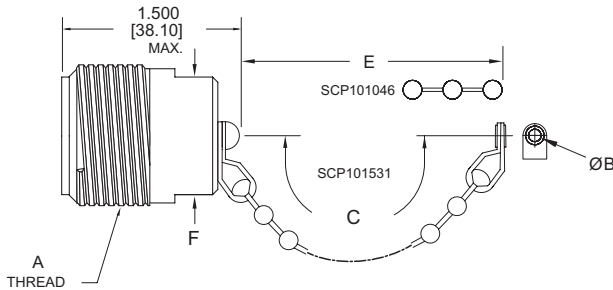

SHELL SIZE	A THREAD CLASS 2A	B DIA +.010 -.000	ØC APPROX	ØD DIA MAX	E APPROX
10	.6250-0.05P-0.1L-DS	.140 [3.56]	3.000 [76.20]	.844 [21.44]	3.375 [85.73]
12	.7500-0.1P-0.2L-DS	.140 [3.56]	3.500 [88.90]	.969 [24.61]	3.875 [98.43]
14	.8750-0.1P-0.2L-DS	.140 [3.56]	3.500 [88.90]	1.094 [27.79]	3.875 [98.43]
16	1.0000-0.1P-0.2L-DS	.140 [3.56]	3.500 [88.90]	1.219 [30.96]	3.875 [98.43]
18	1.1250-0.1P-0.2L-DS	.193 [4.90]	3.500 [88.90]	1.344 [34.14]	4.000 [101.60]
20	1.2500-0.1P-0.2L-DS	.193 [4.90]	4.000 [101.60]	1.469 [37.31]	4.500 [114.30]
22	1.3750-0.1P-0.2L-DS	.193 [4.90]	4.000 [101.60]	1.562 [39.67]	4.500 [114.30]
24	1.5000-0.1P-0.2L-DS	.193 [4.90]	4.500 [114.30]	1.688 [42.88]	5.000 [127.00]
28	1.7500-0.1P-0.2L-DS	.193 [4.90]	4.500 [114.30]	1.938 [49.23]	5.000 [127.00]
32	2.0000-0.1P-0.2L-DS	.193 [4.90]	5.000 [127.00]	2.219 [56.36]	5.500 [139.70]
36	2.2500-0.1P-0.2L-DS	.193 [4.90]	5.000 [127.00]	2.469 [62.71]	5.500 [139.70]
40	2.5000-0.1P-0.2L-DS	.193 [4.90]	5.000 [127.00]	2.719 [69.06]	5.500 [139.70]
44	2.7500-0.1P-0.2L-DS	.193 [4.90]	6.000 [152.40]	2.969 [75.41]	6.000 [152.40]
48	3.0000-0.1P-0.2L-DS	.193 [4.90]	6.000 [152.40]	3.219 [81.76]	6.000 [152.40]

1. Dimensions in brackets [] are in millimeters.

Dust Cap for Receptacle

SCP101046/SCP101531 DCR16

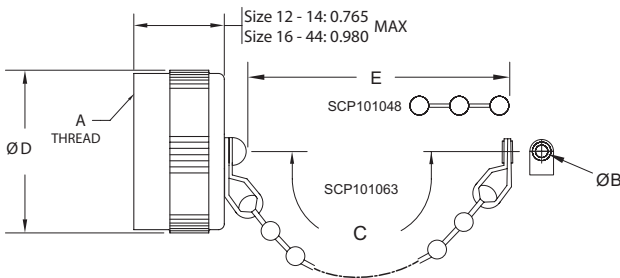

SHELL SIZE	A THREAD CLASS 2A	B DIA +.010 -.000	C APPROX	E APPROX	F ±.010 FLAT
10	.6250-0.05P-0.1L-DS	.125 [3.18]	3.000 [76.20]	3.375 [85.73]	.500 [12.70]
12	.7500-0.1P-0.2L-DS	.125 [3.18]	3.500 [88.90]	3.875 [98.43]	.625 [15.88]
14	.8750-0.1P-0.2L-DS	.125 [3.18]	3.500 [88.90]	3.875 [98.43]	.750 [19.05]
16	1.0000-0.1P-0.2L-DS	.140 [3.56]	3.500 [88.90]	3.875 [98.43]	.875 [22.23]
18	1.1250-0.1P-0.2L-DS	.140 [3.56]	3.500 [88.90]	4.000 [101.60]	1.000 [25.40]
20	1.2500-0.1P-0.2L-DS	.193 [4.90]	4.000 [101.60]	4.500 [114.30]	1.062 [26.97]
22	1.3750-0.1P-0.2L-DS	.193 [4.90]	4.000 [101.60]	4.500 [114.30]	1.125 [28.58]
24	1.5000-0.1P-0.2L-DS	.193 [4.90]	4.500 [114.30]	5.000 [127.00]	1.250 [31.75]
28	1.7500-0.1P-0.2L-DS	.193 [4.90]	4.500 [114.30]	5.000 [127.00]	1.500 [38.10]
32	2.0000-0.1P-0.2L-DS	.193 [4.90]	5.000 [127.00]	5.500 [139.70]	1.750 [44.45]
36	2.2500-0.1P-0.2L-DS	.193 [4.90]	5.000 [127.00]	5.500 [139.70]	2.000 [50.80]
40	2.5000-0.1P-0.2L-DS	.193 [4.90]	5.000 [127.00]	5.500 [139.70]	2.250 [57.15]
44	2.7500-0.1P-0.2L-DS	.193 [4.90]	6.000 [152.40]	6.000 [152.40]	2.500 [63.50]
48	3.0000-0.1P-0.2L-DS	.193 [4.90]	6.000 [152.40]	6.000 [152.40]	2.750 [69.85]

1. Dimensions in brackets [] are in millimeters.

Dummy Receptacle

SCP10750 DRP16

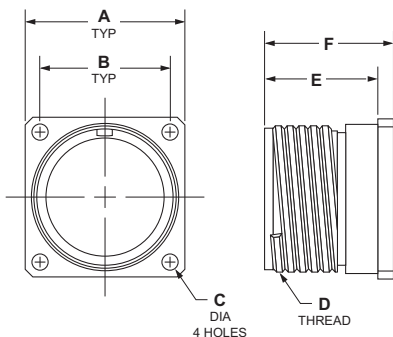
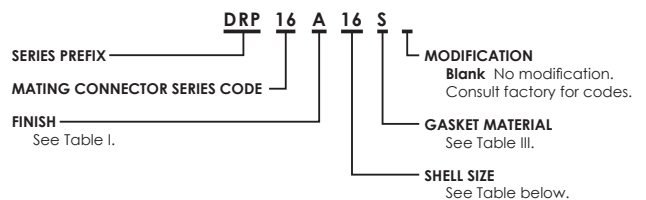
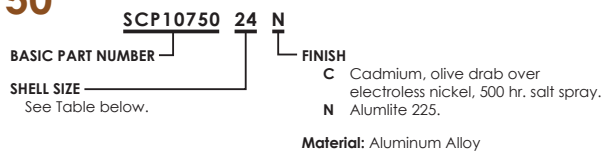

Shell Size	A +.021 -.020	B	C ±.005	D Thread Class 2A	E +.010 -.000	F +.021 -.010
10	1.000 [25.40]	.719 [18.26]	.150 [3.81]	.6250-0.05P-0.1L-DS	.609 [15.47]	.751 [19.08]
12	1.094 [27.79]	.812 [20.62]	.150 [3.81]	.7500-0.1P-0.2L-DS	.609 [15.47]	.750 [19.05]
14	1.188 [30.18]	.906 [23.01]	.150 [3.81]	.8750-0.1P-0.2L-DS	.797 [20.24]	.938 [23.83]
16	1.281 [32.54]	.969 [24.61]	.150 [3.81]	1.000-0.1P-0.2L-DS	.797 [20.24]	.938 [23.83]
18	1.375 [34.93]	1.062 [26.97]	.177 [4.50]	1.1250-0.1P-0.2L-DS	.797 [20.24]	.938 [23.83]
20	1.500 [38.10]	1.156 [29.36]	.177 [4.50]	1.2500-0.1P-0.2L-DS	.797 [20.24]	.953 [24.21]
22	1.625 [41.28]	1.250 [31.75]	.177 [4.50]	1.3750-0.1P-0.2L-DS	.797 [20.24]	.953 [24.21]
24	1.750 [44.45]	1.375 [34.93]	.177 [4.50]	1.5000-0.1P-0.2L-DS	.797 [20.24]	.953 [24.21]
28	2.000 [50.80]	1.562 [39.67]	.177 [4.50]	1.7500-0.1P-0.2L-DS	.859 [21.82]	1.047 [26.59]
32	2.250 [57.15]	1.750 [44.45]	.177 [4.50]	2.0000-0.1P-0.2L-DS	.859 [21.82]	1.047 [26.59]
36	2.500 [63.50]	1.938 [49.23]	.209 [5.31]	2.2500-0.1P-0.2L-DS	.922 [23.42]	1.110 [28.19]
40	2.750 [69.85]	2.188 [55.58]	.209 [5.31]	2.5000-0.1P-0.2L-DS	.922 [23.42]	1.110 [28.19]
44	3.000 [76.20]	2.375 [60.33]	.209 [5.31]	2.7500-0.1P-0.2L-DS	.922 [23.42]	1.110 [28.19]
48	3.250 [82.55]	2.625 [66.68]	.209 [5.31]	3.0000-0.1P-0.2L-DS	.922 [23.42]	1.109 [28.17]

1. Dimensions in brackets [] are in millimeters.



**SPACECRAFT
COMPONENTS CORP.**

3040 Clayton Street
North Las Vegas, NV 89032

Phone: 702.851.7600
Fax: 702.851.7620

Email: salesinfo@spacecraft.com
Web: www.spacecraft.com

SPACECRAFT CODES FOR:
 DUST CAP FOR PLUG: **DCP16**
 DUST CAP FOR RECEPTACLE: **DCR16**
 DUMMY RECEPTACLE: **DRP16**

TABLE I. FINISH CODES
 CONSULT FACTORY FOR OTHER AVAILABLE FINISHES

Spacecraft Code	Finish	Specification(s)
H	● Anodize, Black	AMS-A-8625, Type II, Class 2
B	● Cadmium Plate, Black	AMS-QQ-P-416, Type II, Class 3
X	● Cadmium Plate, Bright Over Electroless Nickel	AMS-QQ-P-416, Type I, Class 3 ASTMB 733-90, SC2, Type I, Class 5 over AMS-C-26074, Class 4, Grade B
E	● Cadmium Plate, Gold Iridite, Over Electroless Nickel	MIL-C-5541, Class 3 AMS-QQ-P-416, Type II, Class 3 over AMS-C-26074, Class 4, Grade B
C	● Cadmium Plate, Olive Drab	AMS-QQ-P-416, Type II, Class 3, 48 Hours
A	● Cadmium Plate, Olive Drab Over Electroless Nickel	1000 Hour Corrosion Resistance
N	● Electroless Nickel	AMS-C-26074, Class 4, Grade B
L	● Zinc Cobalt, Dark Olive Drab	96 Hour Corrosion Resistance
P	● Passivated, Stainless Steel	AMS-QQ-P-35
T	● Nickel, Fluorocarbon Polymer	500 Hour Corrosion Resistance
W	● Zinc Nickel, Black	ASTM B841 Type D

TABLE II. ATTACHMENT CODES

Attachment Code	Description
A	No Attachment Required
B	Bead Chain, Brass, Nickel Plated
C	Sash Chain, SST, Passivated
D	Bead Chain, SST, Passivated
E	Bead Chain, Brass, Cadmium, Olive Drab Plated
F	Bead Chain, Brass, Unfinished
I	Bead Chain, Brass, Black Oxide Finish
N	Wire Rope, No Jacket
P	Wire Rope, Polyurethane Jacket with Terminal
R	Wire Rope, SST, PVC Covered, Green Color
T	Wire Rope, SST, Teflon Covered, Natural Cover
U	Wire Rope, SST, Nylon Covered, Brown Color
V	Wire Rope, SST, Viton Covered, Black Color
W	Nylon Cord, Green Color, SST Terminal

TABLE III. GASKET MATERIAL CODES

Material Code	Material Description
A	Fluorosilicone, Blue
N	Neoprene, Black, MIL-R-3065
O	None Required
S	Silicone, Red, ZZ-R-765
C	Conductive Silicone

TABLE IV. EYELET END FITTING STYLES AND SIZES (NOT USED WITH ATTACHMENT CODE A)

Dash No. Code	Y Ref. Dia.
00	No Eyelet
01	.125
02	.141
03	.167
04	.188
05	.219
06	.250
07	.156
08	.121

USED WITH ATTACHMENT CODES:

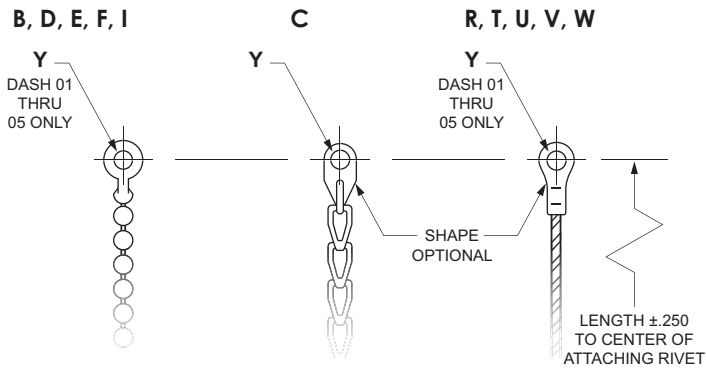
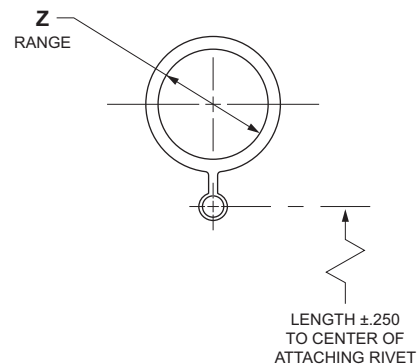

TABLE V. RING END FITTING SIZES (NOT USED WITH ATTACHMENT CODE A)

DASH NO. CODE	Z RANGE	DASH NO. CODE	Z RANGE	DASH NO. CODE	Z RANGE
33	.401 - .391	15	1.072 - 1.052	24	2.088 - 2.078
34	.454 - .444	16	1.198 - 1.178	25	2.151 - 2.141
35	.464 - .454	17	1.322 - 1.302	26	2.276 - 2.266
36	.526 - .516	18	1.448 - 1.428	27	2.338 - 2.328
11	.604 - .584	19	1.572 - 1.552	28	2.401 - 2.391
37	.651 - .641	20	1.698 - 1.678	29	2.526 - 2.516
12	.729 - .709	21	1.822 - 1.802	30	2.651 - 2.641
13	.885 - .865	22	1.948 - 1.928	31	2.901 - 2.891
14	.948 - .918	23	2.026 - 2.016	32	3.026 - 3.016

USED WITH ATTACHMENT CODES: **B THRU W**



SPACECRAFT COMPONENTS CORP.

Your Connector Consultant Since 1962

Try Our Other Connector Products



SCP 5015 STYLE CONNECTORS (CATALOG 102)



SCPT 26482 STYLE SC1 38999 SERIES I SC2 38999 SERIES II SC39 38999 SERIES III (CATALOG 202)



SCPB SERIES (CATALOG 302)



CONNECTOR ACCESSORIES (CATALOG 402)



CONNECTORS WITH INTEGRATED BACKSHELLS (CATALOG 601)



Get All of Our Catalogs & Product Brochures on One Disc



SPACECRAFT COMPONENTS CORP.



Headquarters

3040 Clayton Street
North Las Vegas, NV 89032

Phone: 702.851.7600
Fax: 702.851.7620

Email: salesinfo@spacecraft.com
Web: www.spacecraft.com

Florida Office

4577 Nob Hill Road
Suite 106
Sunrise, FL 33351
Tel: 954.748.4540
Fax: 954.748.4128

Arizona Office

519 W. Lone Cactus Dr.
Suite 401
Phoenix, AZ 85027
Tel: 623.580.1162
Fax: 623.580.1165

Italy Office

Spacecraft Components, sp A
Milan, Italy
+39 [335] 719.4512

Mexico Office

Av. Constituyentes 13-6 Col. Pueblo Nuevo
Queretaro, Qro 76900
+52 442 341 69 63

APR 2013
SF-150

COMPILED AND PRODUCED BY SPACECRAFT COMPONENTS CORP.
©2012 SPACECRAFT COMPONENTS CORP., NORTH LAS VEGAS, NV 89032