

INCH-POUND

MIL-PRF-83536/33B
8 March 2010
SUPERSEDING
MIL-PRF-83536/33A
1 March 2005

PERFORMANCE SPECIFICATION SHEET

RELAYS, ELECTROMAGNETIC, ESTABLISHED RELIABILITY, 3PDT,
25 AMPERES (RESISTIVE), PERMANENT MAGNET DRIVE, HERMETICALLY SEALED,
ALL WELDED, TRANSIENT SUPPRESSED DC COIL

This specification is approved for use by all Departments and
Agencies of the Department of Defense.

The requirements for acquiring the product described herein shall consist of this
specification and [MIL-PRF-83536](#).

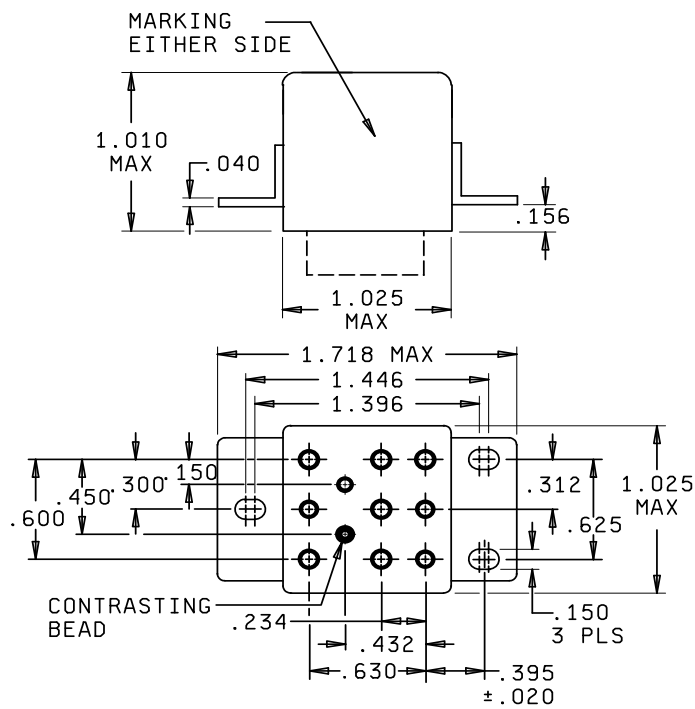

Raised Vertical Flange Mount (RVFM)

SOLDER HOOK, SOLDER PIN, AND SOCKET PIN RELAYS

FIGURE 1. Configurations and dimensions

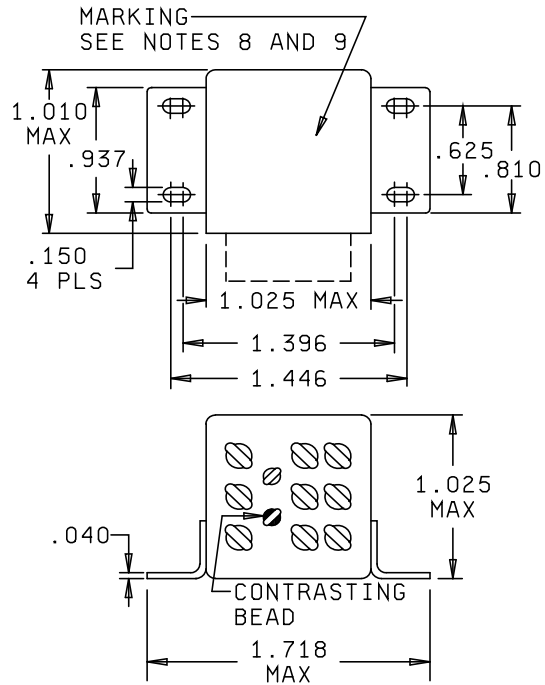

Horizontal Flange Mount (HFM)

SOLDER HOOK AND SOLDER PIN RELAYS, TIN PLATE FINISH

FIGURE 1. Configurations and dimensions - Continued.

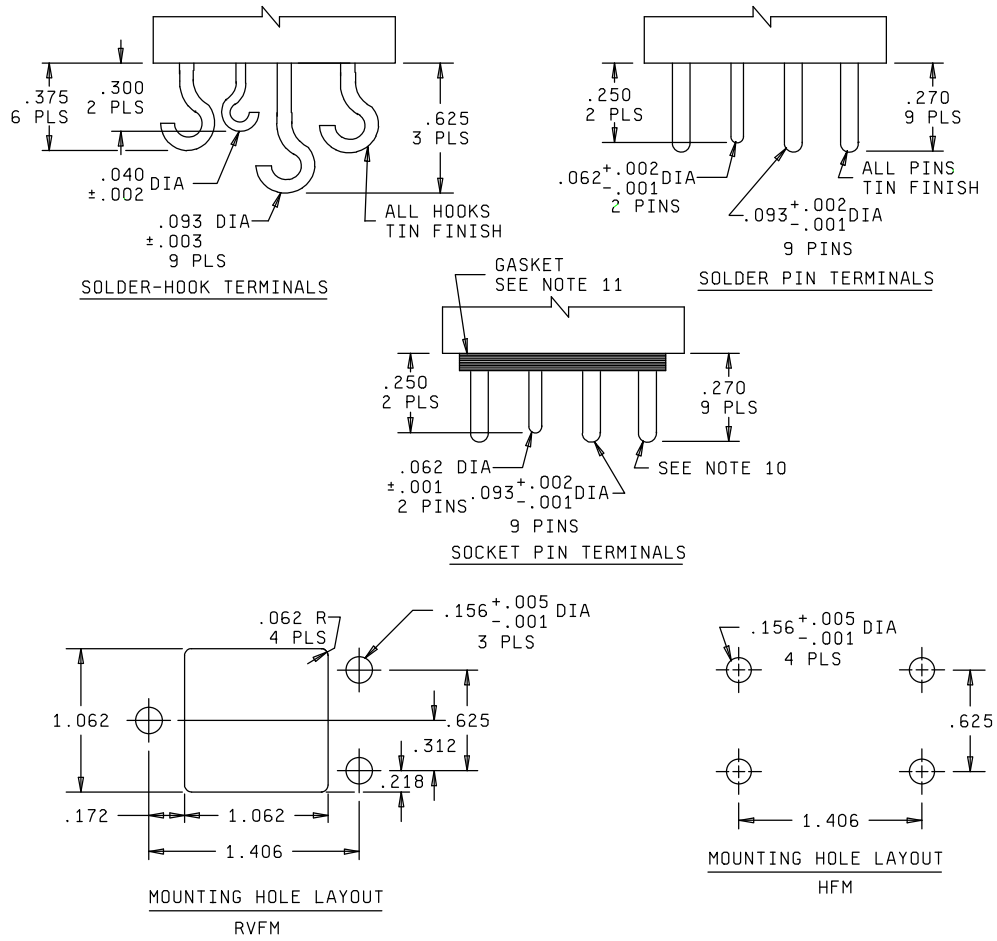
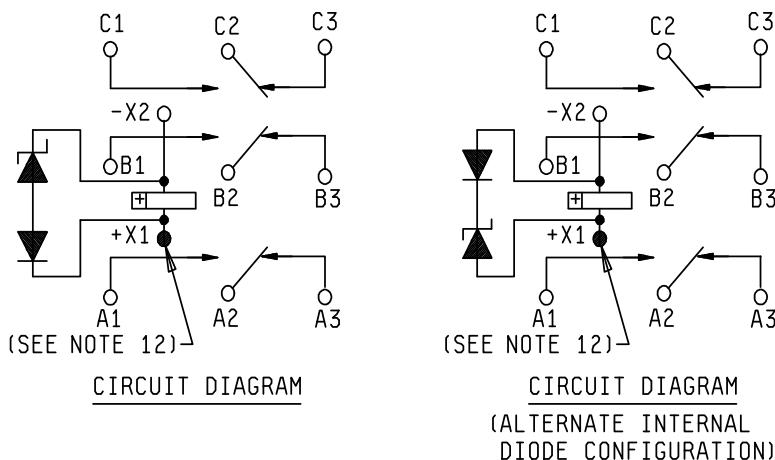

FIGURE 1. Configurations and dimensions - Continued.

MIL-PRF-83536/33B



Inches	mm	Inches	mm	Inches	mm
.001	0.03	.218	5.54	.625	15.88
.003	0.08	.234	5.94	.630	16.00
.005	0.13	.250	6.35	.810	20.57
.020	0.51	.270	6.86	.937	23.80
.040	1.02	.300	7.62	1.010	25.65
.050	1.27	.312	7.96	1.025	26.04
.062	1.57	.375	9.53	1.062	26.98
.093	2.36	.395	10.03	1.396	35.46
.150	3.81	.432	10.97	1.406	35.71
.156	3.96	.450	11.43	1.446	36.73
.172	4.37	.600	15.24	1.718	43.64

NOTES:

1. Dimensions are in inches.
2. Metric equivalents are given for general information only.
3. Unless otherwise specified, tolerance is ± 0.020 (0.51 mm).
4. There shall be affixed to the relay a suitable circuit diagram that identifies each terminal location specified.
5. These relays are polarized monostable.
6. Relays must not operate or be damaged by reverse polarity.
7. Permanent magnet drive consists of a permanent magnet with its flux path switched and combined with the electromagnet flux.
8. Applicable to horizontal flange mount only. The manufacturer's PIN, circuit diagram, and military PIN shall be marked on the near side. The remaining of the nameplate data shall be marked on the far side.
9. Applicable to horizontal flange mount only. Relays shall be marked with the manufacturer's name or CAGE code and date code on the top of the can. Marking shall be with the bottom of the print adjacent to the near side.
10. Socket pin terminals shall provide the operational, environmental, and interface characteristics to provide a reliable interconnect to gold-plated contacts. Socket pin terminals, except for the polarizing pin, shall be gold plated. One system for gold plating that may be used is [ASTM B488](#), type 3, class 1.25 with a nickel underplate of 50 to 150 microinches thick. The gold plating system shall enable the product to meet the performance requirements of this specification and shall be approved by the qualifying activity.
11. Gasket shall provide a reliable seal between the relay and mating socket that will meet the environmental, operational, and interface requirements of the relay with the mating socket. The gasket shall have shore hardness 15 to 35, thickness $.050 \pm 0.005$. Gasket material according to [SAE-AMS 3332](#) has been considered acceptable. Gaskets are not supplied with track mount relays.
12. Indicated terminals shall be identified by contrasting beads.
13. Back EMF (transient voltage): 42 V dc maximum.

FIGURE 1. Configurations and dimensions - Continued.

REQUIREMENTS:

Contact data:

Load ratings: See [table I](#).

Intermediate current: Applicable.

Mixed loads: Applicable.

Low level life: Not applicable.

TABLE I. Rated contact load and cycles (amperes per pole) .

Type of load (high level)	Life operating cycles x 10 ³	28 V dc	115 V ac 1 phase 400 Hz	115 V ac 1 phase 50/60 Hz	115/200 V ac 3 phase 400 Hz	115/200 V ac 3 phase 50/60 Hz
Resistive	50	25	25	N/A	25	N/A
Inductive	10	12	N/A	N/A	N/A	N/A
Inductive	20	N/A	15	N/A	15	N/A
Motor	50	10	10	N/A	10	N/A
Lamp	50	5	5	N/A	5	N/A
Mechanical	200	6	6	N/A	6	N/A

Life: 50,000 cycles, unless otherwise specified (see [table I](#)).

Contact voltage drop or resistance:

Initial contact voltage drop: 0.150 V maximum. Rated resistive current at 6 V dc or peak ac. Relays shall not make or break this load.

Initial contact resistance: Not applicable.

High level life (contact voltage drop):

During life: 10 percent open circuit voltage maximum.

After life: 0.175 V maximum.

Intermediate current (contact resistance):

During intermediate current: 3 ohms maximum.

After intermediate current: 0.150 ohm maximum.

Contact bounce: 1.0 ms maximum

Contact break bounce: 0.1 ms maximum.

Contact stabilization time: Deleted.

Overload current: 50 A dc, 80 A ac.

Rupture current: 60 A dc, 100 A ac.

Time current relay characteristics: See [table II](#).

TABLE II. Time current relay characteristics . [1/](#)

Successive application	Amperes	Time
1	30	1 hour
2	50	5.0 seconds
3	100	1.2 seconds
4	250	0.2 seconds
5	350	0.1 seconds

[1/](#) All relays shall withstand overload and fault currents. Relays must be able to sustain five applications (make and carry only) of power concurrently on adjacent poles at each of five different current levels in the sequence listed in [table II](#). Separate relays shall be tested at 28 V dc and 115/200 V ac, 400 Hz, 3 phase. Cooling time between successive applications shall be 30 minutes. Tests shall be performed on both normally open and normally closed contacts. There shall be no failures or evidence of welding or sticking and relays shall pass contact voltage drop at the conclusion.

Coil data [1/](#): See [table III](#).

Operate time: 15 ms maximum with rated coil voltage over the temperature range.

Release time: 15 ms maximum from rated coil voltage over the temperature range.

Duty rating: Continuous.

Coil transient suppression: Applicable; 42 V dc maximum.

Neutral screen: Not applicable.

Dash number and general characteristics: See [table III](#).

TABLE III. Dash numbers and characteristics.

Dash number <u>1/</u>			Mount	Coil data										
Solder pin	Solder hook	Socket pin		At 25°C						Over temperature range			Maximum pickup	
				Coil voltage (V dc) <u>2/</u>		Coil resistance Ω minimum	Specified pickup voltage (V dc) <u>3/</u>	Specified hold voltage (V dc) <u>3/</u>	Specified dropout voltage (V dc) <u>3/</u>	Specified pickup voltage (V dc) <u>3/</u>	Specified hold voltage (V dc) <u>3/</u>	Specified dropout voltage (V dc) <u>3/</u>	High temperature test	Continuous current test
Rated	Max													
001	002	003	RVFM	28	29 <u>4/</u>	260	13.5	5.5	2.3	18.0	7.0	1.5	19.8	22.5
004	005	---	HFM	28	29 <u>4/</u>	260	13.5	5.5	2.3	18.0	7.0	1.5	19.8	22.5

1/ The suffix letter L, M, P, or R to designate the applicable failure rate level shall be added to the applicable dash number. Failure rate levels (percent per 10,000 cycles): L, 3.0; M, 1.0; P, 0.1; R, 0.01. Examples: 001L, 002R.

2/ CAUTION: The use of any coil voltages less than the rated coil voltage will compromise the operation of the relay.

3/ Pickup, hold, and dropout voltages are shown for test purposes only and are not to be used as design criteria.

4/ When maximum ambient temperature does not exceed +85°C, the maximum coil voltage shall be 32 V dc.

Electrical data:

Insulation resistance:

Initial: 100 megohms minimum at 500 V dc.

After life or environmental tests: 50 megohms minimum at 500 V dc.

Dielectric withstanding voltage: 2/

	Coil to Case	All other points
Sea level:		
Initial:	1,000	1,250
After life:	1,000	1,000
Altitude:		
At 300,000 feet:	500	500

Environmental characteristics:

Temperature range: -70°C to +125°C.

Maximum altitude rating: 300,000 feet.

Shock (specified pulse): Applicable: Method 213, MIL-STD-202, test condition C, 200 g's for 6 ms ±1 ms, except horizontal flange mount peak g value shall be 100 g's for 6 ms ±1 ms. Contact chatter shall not exceed 10 microseconds maximum for closed contacts and 1 microsecond maximum closure for open contacts.

Vibration (sinusoidal): Applicable: Method 204, MIL-STD-202, 30 g's, except frequency range shall be 10 Hz to 3,000 Hz. Horizontal flange mount shall be 20 g's, 57 Hz to 3,000 Hz. Contact chatter shall not exceed 10 microseconds maximum for closed contacts and 1 microsecond maximum closure for open contacts.

Vibration (random): Applicable to qualification and group C inspection. Test in accordance with method 214, MIL-STD-202, test condition IG (0.4 g² / Hz, 50 Hz to 2,000 Hz); for horizontal flange mount, test condition IE (0.2 g² / Hz) shall be used. Contact chatter shall not exceed 10 microseconds maximum for closed contacts and 1 microsecond maximum closure for open contacts.

Acceleration: Applicable, except 15 g's.

Physical data:

Dimensions and configurations: See figure 1.

Weight: 0.18 pound maximum (82 grams).

2/ Dielectric may be improved by suitable insulation of terminals and wiring after installation.

Terminal strength:

Solder hook terminals:

Pull force: 10 pounds \pm 1.0 pound.

Bend: Not applicable to leads .047 diameter (1.19 mm) and larger.

Twist: Not applicable.

Solder pin terminals:

Pull force: For .062 diameter terminals: 10 pounds \pm 1.0 pound.

Bend: Not applicable to leads .047 diameter (1.19 mm) and larger.

Twist: Not applicable.

Socket pin terminals:

Pull force: For .062 diameter terminals: 10 pounds \pm 1.0 pound.

Bend: Not applicable to leads .047 diameter (1.19 mm) and larger.

Twist: Not applicable.

Terminal solderability: Applicable to solder pin and solder hook terminals only.

Seal: Hermetic.

Marking: Applicable.

Part or Identifying Number (PIN): M83536/33 (plus a dash number from [table III](#) and a suffix letter designating failure rate level).

Qualification inspection:

Qualification inspection and sample size: See [MIL-PRF-83536](#).

Qualification inspection (reduced testing) (sample size - 2 units each coil voltage and 1 unsealed unit). See [table IV](#).

If the relay produced for [MIL-PRF-83536/32](#) is similar in construction and design except for the suppression network to the relays produced for the MIL-PRF-83536/33, then reduced testing for qualification of [MIL-PRF-83536/32](#) relays may be performed concurrent with or subsequent to successful qualification of MIL-PRF-83536/33 relays. For reduced testing see [table IV](#).

TABLE IV. Qualification inspection (reduced testing) .

Inspection
2 units each coil voltage Group Q1 of qualification inspection table 1 unsealed sample unit for internal inspection

Supersession data: See [table V](#).

TABLE V. Supersession data.

Superseded PIN MS27743-	Replacement PIN M83536/33-
32, 34	001
22, 16	002
18, 24	003
33, 35	004
23, 17	005

Referenced documents. In addition to [MIL-PRF-83536](#), this document references the following:

[MIL-STD-202](#)
[ASTM-B488](#)

[MIL-PRF-83536/32](#)
[SAE-AMS3332](#)

Changes from previous issue: The margins of this specification are marked with vertical lines to indicate where changes from the previous issue were made. This was done as a convenience only and the Government assumes no liability whatsoever for any inaccuracies in these notations. Bidders and contractors are cautioned to evaluate the requirements of this document based on the entire content irrespective of the marginal notations and relationship to the last previous issue.

Custodians:
Army - CR
Navy - EC
Air Force – 85
DLA - CC

Preparing activity:
DLA - CC

Review activities:
Air Force - 99

(Project 5945-2010-019)

NOTE: The activities listed above were interested in this document as of the date of this document. Since organizations and responsibilities can change, you should verify the currency and information above using the ASSIST Online database at <https://assist.daps.dla.mil>.