

MOMENTARY ACTION COMMERCIAL GRADE LED ILLUMINATED & WATERTIGHT SEALED

The OTTO LP9 Lighted Dome series is a quality precision switch designed for use in panels, control grips, instruments, heavy equipment and other demanding applications where attractive, rugged, lighted pushbutton switches are required.

The LP9 series offers a positive tactile feedback, signaling the operator when the switch is operated with the added benefit of reliable LED illumination. The LP9 series offers four button versions; flush and raised profile with either a glossy or matte finish. It also comes with a threaded case for hex nut mounting while providing a short behind panel depth.

The LP9 series is constructed to meet IP68S watertight seal. Expect 25,000 operations at full rated load of 5 amps resistive or 3 amps inductive; 500,000 operations at 500mA/200mA resistive.

The LP9 series are momentary snap-action double break switches, available in standard and low operate forces. The LED is available in five colors and has the ability to accommodate 2 or 12VDC.

Features:

- **Watertight to IP68S**
- **LED lighted with the ability to accommodate 2 or 12VDC**
- **LED available in five colors**
- **Flush & raised button style**
- **Matte & glossy button finish**
- **Positive tactile feedback contact transfer**
- **Withstands extreme shock & vibration**
- **Short behind panel depth**

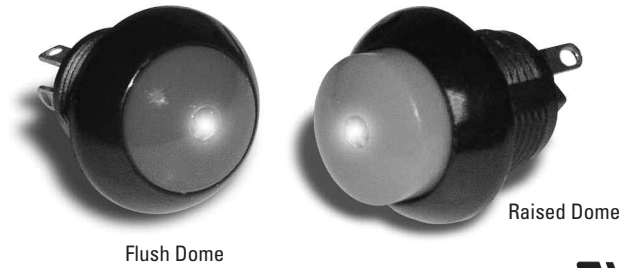

Standard Characteristics/Ratings:			
ELECTRICAL RATINGS: Sea Level @ 28VDC or 115VAC, 60/400Hz			
Load	N.O./N.C.	Cycles	Operating Force
Resistive	5A	25,000	Standard
Inductive	3A	25,000	Standard
Resistive	500mA	500,000	Standard
Resistive	200mA	500,000	Low or Standard
DVV	1050Vrms		
Low Level	10mA @ 30mV	25,000	
Electrical Life:		See Rating Chart	
LIGHTING:			
Light Source Voltage (DC)	Actual Voltage Nominal (DC)	Voltage Max (DC)	
2	2	2.6	
12	13.5	14.5	
Mechanical Life:		1,000,000 cycles	
Seal:		IP68S	
Operating Temp Range:		-55°C to +85°C	
Operating Force:		1.7 +/- 0.5 lb. (standard force) 12 +/- 4 oz (low force)	
Total Travel:		0.080 inches max	
Overtravel:		0.010 inches min	
MATERIALS:			
Case:		Thermoplastic	
Button:		Thermoplastic	
Terminals:		Brass with gold plate over silver plate	
Mounting Hardware:		Hex nut and lockwasher for round/threaded style case only Panel gasket for snap-in style case only	

LP9 PART NUMBER CODE

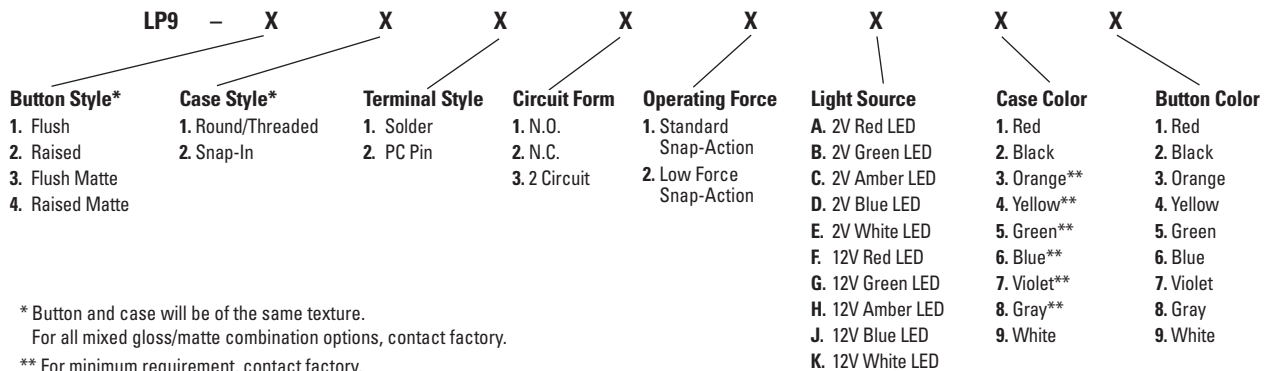

ILLUMINATED SEALED DOME PUSHBUTTONS

LP9
ILLUMINATED
PUSHBUTTONS

MOMENTARY ACTION COMMERCIAL GRADE LED ILLUMINATED & WATERTIGHT SEALED

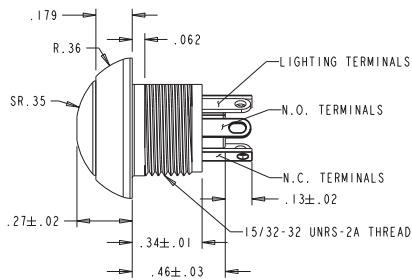

Round Threaded Case Style, Flush Button

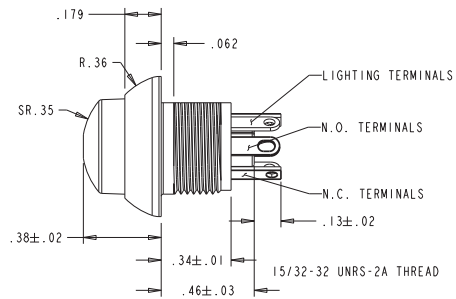

Round Threaded Case Style, Raised Button

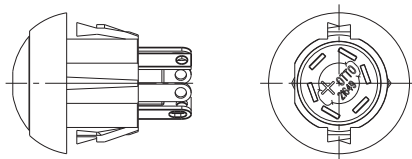

Snap-In Case Style, Flush Button

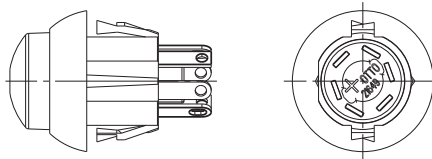

Snap-In Case Style, Raised Button

**Standard Terminals
(Terminals not oriented to flat.)**

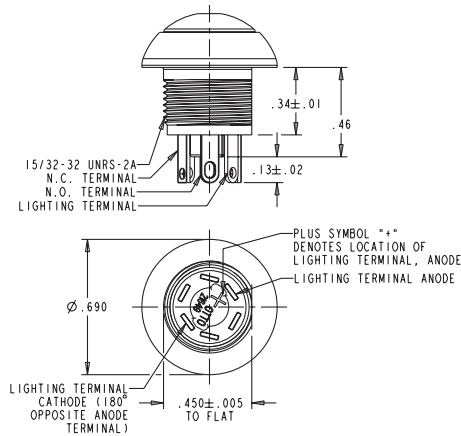

**PC Terminals
(Orientated to case flats as shown.)**

